

Pocket Loks®

Installation Instructions

Ford F250 / 350 Super Duty '99 to Date

Dodge Ram '02 to Date

Before installing the Pocket Loks®, cut the non-removable stake pocket cover with a knife. Make a cut NO Larger that the stake pocket hole in the truck bed rail.

1. Slip the Carriage Bolt through the Anchor Bracket and thread into the bottom of the Anchor Plate.
2. Place the Locator Plate, rib side down, on top of the Anchor Plate, wide side up.
3. Fasten the two plates together with two (2) 10-32 screws (provided) through both the Anchor Plate and the grooves in the Anchor Bracket. Leave the two plates approximately 1/2 inch apart.
4. Insert the Anchor Plate into the stake pocket with a rocking motion. Place the Pocket Lok® into the opening as if there were no plastic rail cap.
5. The Locator Plate will rest on top of the plastic rail cap with the anchor plate down inside the truck bed rail.
6. Tighten the two (2) screws until snug. Do not over-tighten.
7. Mount the product to the Carriage Bolt on the completed Pocket Lok® Assembly and secure with a Nyloc Hex Nut.

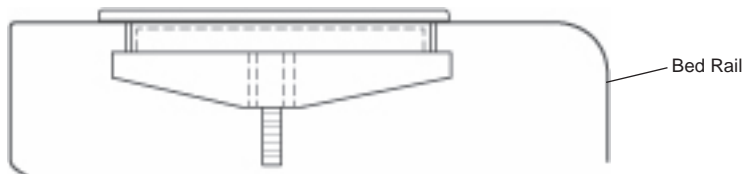
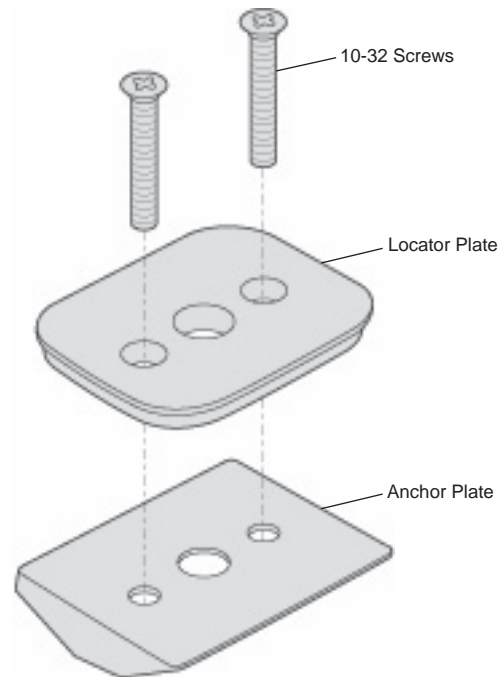

Note: When installing rack or other accessory to Pocket Loks®, make sure the studs are clean. Using a dirty stud may cause stud to seize up in Anchor Plate. DO NOT torque attaching bolt or stud over 18 foot pounds.

