



Replacement Top Installation Instructions

For: 1998 and newer Isuzu Amigo

Part Number: 51157



WARNING

This product is designed to enhance the appearance of the vehicle and to shield the occupants from ordinary weather conditions. Do not rely in any way on the components of this product to contain occupants within the vehicle, or to protect against injury or death in the event of an accident. This top will not protect the occupants from falling objects. Never operate vehicle in excess of manufacturer's specifications.

WEAR SEAT BELTS AT ALL TIMES

Read and follow, precisely, all installation instructions provided when installing top. Failure to do so may result in a poor fitting top and could place occupants of the vehicle in a potentially dangerous situation.

Installation Tips

Before you begin installing this top assembly, read all instructions thoroughly. After completing the installation, keep these instructions for further reference. Below are a few tips to make this installation easier.

For a smooth fit:

For ease in installation, the top should be installed at temperatures above 72° F. Below this temperature, the top may contract an inch or more, making it difficult to fit to the vehicle.

It is normal for a top to contract and wrinkle when stored in the shipping carton. Within a few days after the installation, the top will relax and the wrinkles will disappear.

Parts List

Top Fabric	Qty - 1
Quarter Window, Rt.	Qty - 1
Quarter Window, Lt.	Qty - 1
Rear Window	Qty - 1

Tools Needed

Phillips Screwdriver
4mm Allen Wrench
Safety Glasses

Removing the Old Top



Caution

Safety glasses should be worn at all times while installing this product.

Step One

Remove the Quarter Windows and the Rear Window. Set the tailgate retainer bar aside to be reused later. Pull gently down and out on the fabric to release the plastic in the rear corners of the top from the retainers on the vehicle. Unsnap the fabric from the rear bow and unfasten the hook and loop strips that secure the middle bow. Release the latches that secure the header to the vehicle and allow the bows to collapse toward the rear of the vehicle. Unsnap the front edge of the top fabric from the header. Remove the top from the vehicle.

Step Two

Remove the fabric cover from the front bow on each side of the vehicle. Use a phillips screwdriver to loosen the front screw on the Bow Mount Cover inside the vehicle. This should allow you to pull the Trim Lock away from the vehicle and remove the fabric cover. If the Trim Lock is too firmly caught under the Bow Mount Cover you may need to use a 4mm allen wrench to loosen the rear bolt and remove the inside cover from the bow mount.

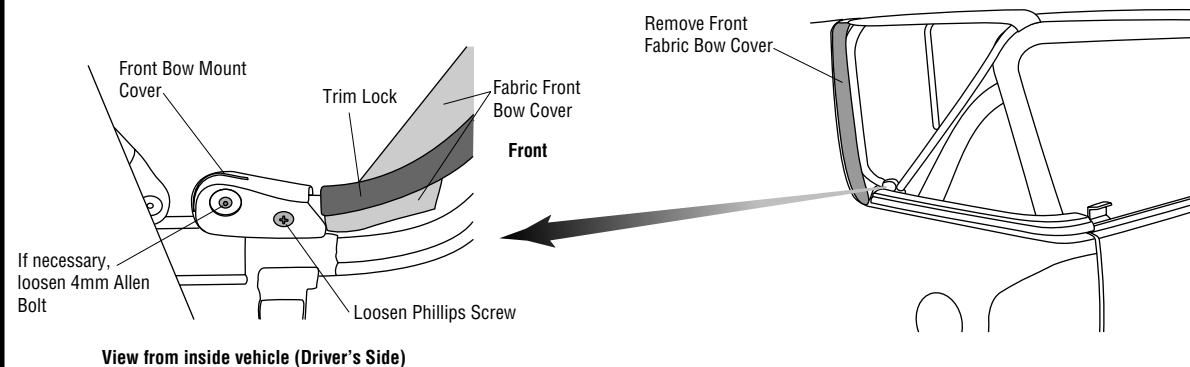

Step Three

Once the fabric covers are removed from the front bow, pinch the channel on the Trim Lock so that it will fit tightly over the metal edge. Start at the top and press the Trim Lock firmly into place along the metal edge working down to the Bow Mount.

The end of the Trim Lock may reach under the Front Bow Mount Cover. If this is the case it may be necessary to remove the Bow Mount Cover completely to allow the Trim Lock to lay flat along the metal edge. Remove the Phillips Screw and the 4mm Bolt in the cover and lift off the cover. Work the Trim Lock into place and replace the cover over the Trim Lock. Tighten the Phillips Screw and the 4mm Allen Bolt (see Step One).

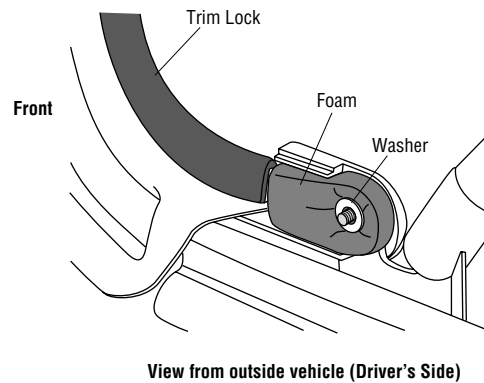

Note: If you need to completely remove the Bow Mount Cover, make sure that the Washer and the foam inside the mount remain in place.

Installing the New Top

Step One

Lay the bow assembly down on the rear of the vehicle. From the rear of the vehicle, hold the top fabric with the snaps along the front edge up and the inside of the fabric toward the vehicle. Slip the pocket along the front edge of the top over the front edge of the header and snap the seven snaps, starting with the center five snaps and then fastening the two outside snaps.

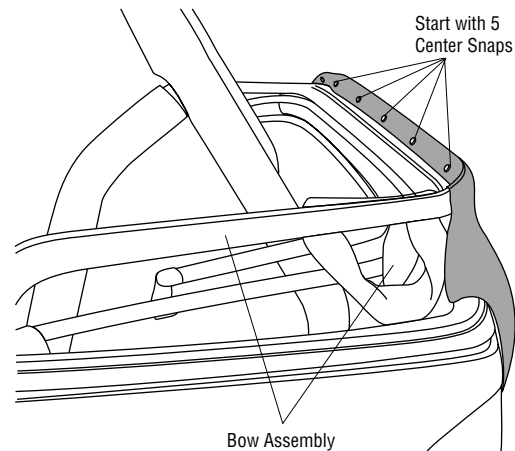

Step Two

Raise the bow assembly and fit the rear bow into the seam along the rear of the top above the rear window opening. Locate the seven snap tabs. Wrap the five center tabs around the rear bow from the rear and snap them to the bow. Then wrap the two outside tabs around the bow from inside and snap them to the bow.

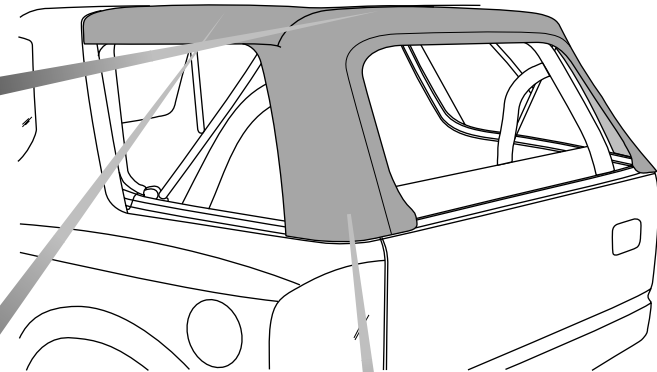
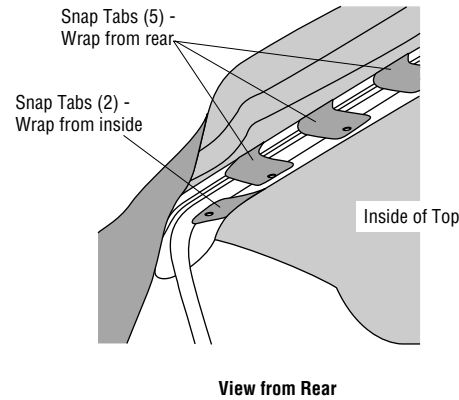

Step Three

Locate the two pairs of hook and loop strips sewn inside the top. Wrap the strips around the middle bow and fasten them to each other.

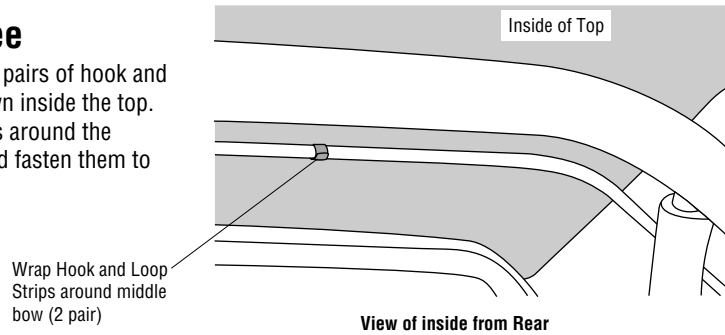

Step Four

Locate the plastic strips sewn to the bottom of the rear legs of the top. Align the notch in the strip with the pin in the retainer mounted on the vehicle and slip the plastic strip under the retainer.

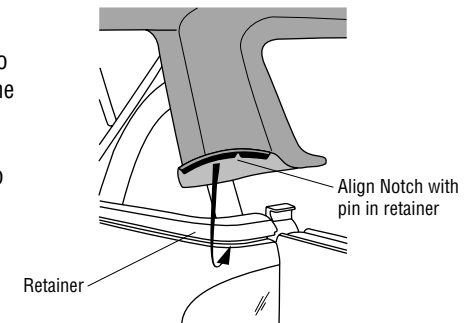

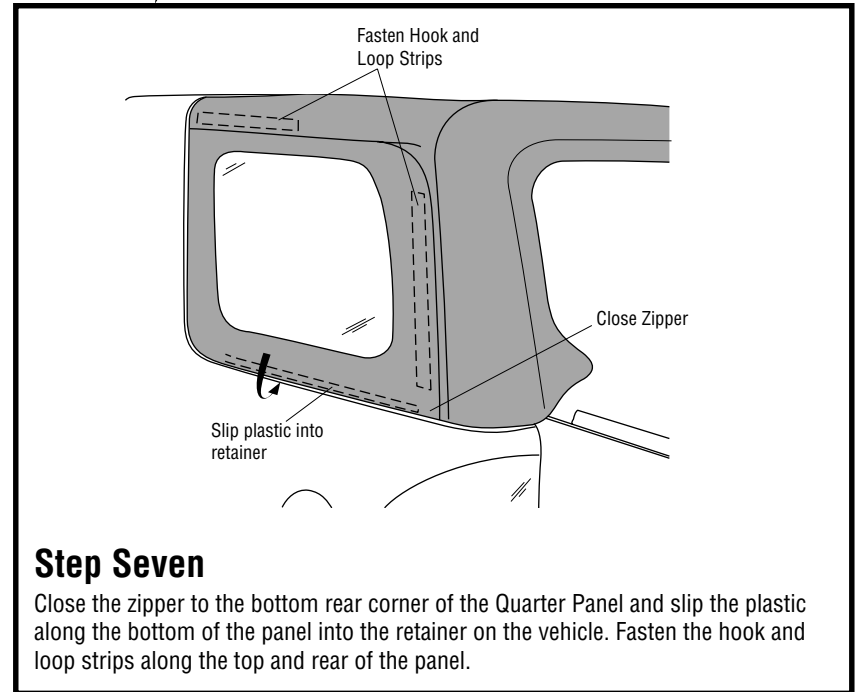
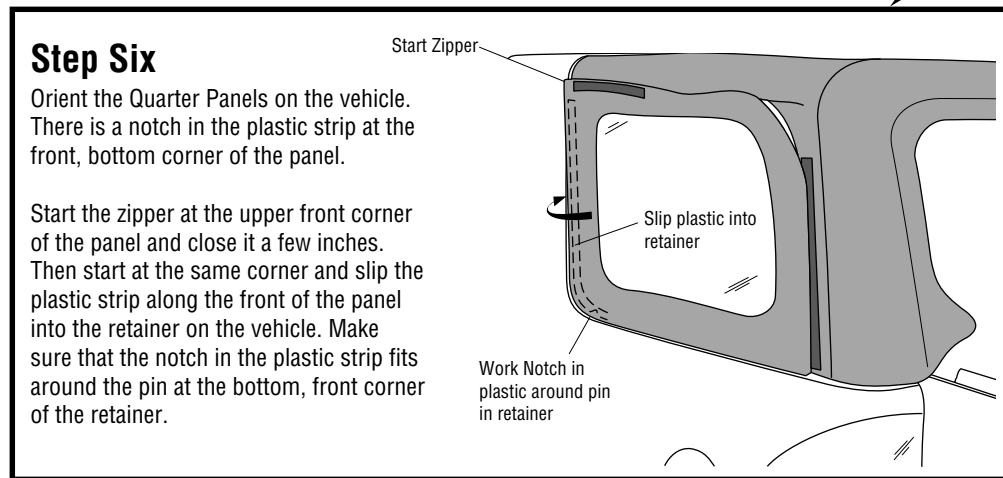
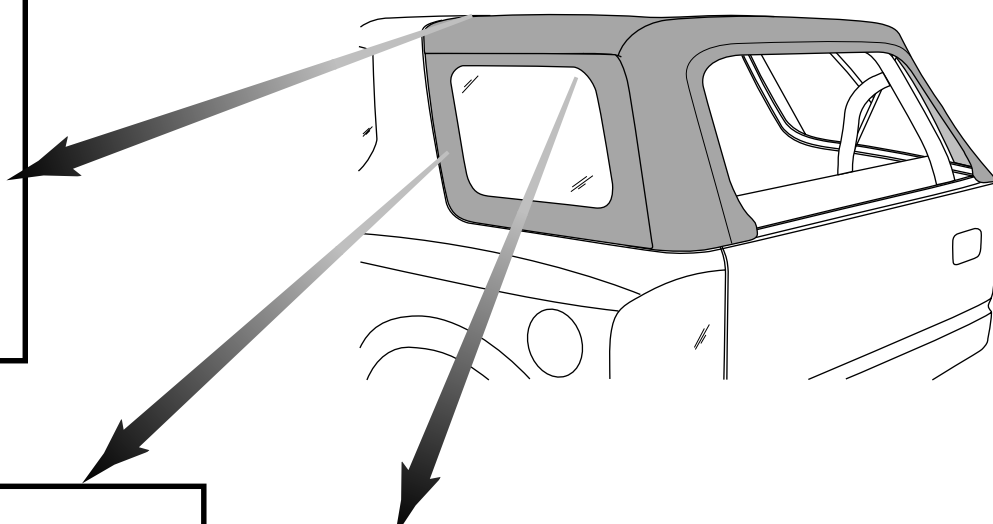
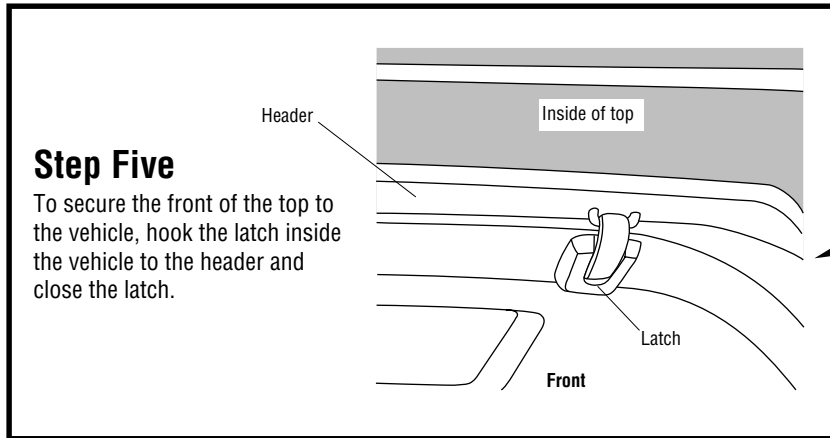

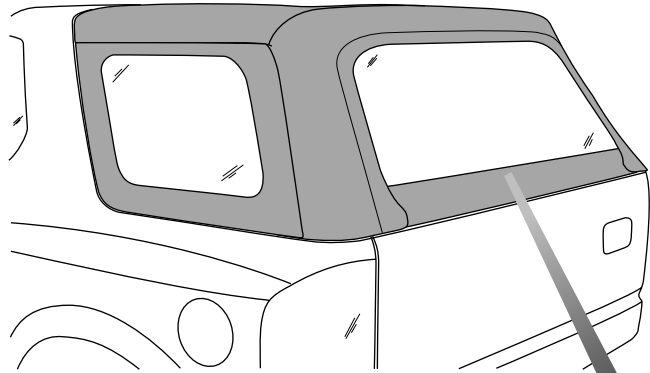

Detail of Tailgate Retainer Bar Orientation

Notch

Inside of Vehicle

Outside of Vehicle

Fasten Hook and Loop Strips

Start Zipper Here

Top Fabric

Rear Window

Notch

Tailgate Retainer Mount

Tailgate Retainer Bar

View from Inside Vehicle

Step Eight

Orient the Rear Window with the zipper on top and the vinyl toward you. Start the zipper on the driver's side and close it to the upper corner on the passenger side.

Locate the Tailgate Retainer Bar and orient it with the angled side toward the top, outside of the vehicle. Start on the passenger side and slide the bar onto the bottom of the Rear Window. Center the bar in the tailgate opening and slide the ends of the bar into the tailgate retainer mounts on the vehicle. The square notch in the Tailgate Retainer Bar must fit over the raised shape on the mount and lock into place.

Close the zipper all the way. Fasten the hook and loop strips on each side of the Rear Window. Close the tailgate.

Care and Maintenance of your Bestop Top

Your top is made of the finest materials available. To keep it looking new and for the maximum possible wear, it will need periodic cleaning and maintenance.

Washing: The top fabric should be washed often using soap, warm water and a soft bristle brush. Rinse with clear water to remove all traces of soap.

Windows: Keep windows clean to avoid scratching. DO NOT use a brush on the windows! Wash with a watersoaked cloth or sponge and a mild dishwashing detergent. NEVER WIPE THE WINDOWS WHEN THEY ARE DRY. Be careful when cleaning snow or frost from the vinyl windows since they are easily scratched and may crack at low temperatures. DO NOT roll the sides or rear window in cold weather. The windows become stiff and will crack.

Zippers: Keeping the zipper cleaned and lubricated with a silicone lubricant will help prevent damage and keep the zippers in a smooth working condition. If a zipper opens behind the slider, the slider may have been spread apart. This problem can usually be repaired by using an ordinary pair of pliers to bring the sides back into parallel. Return slider to the end of the zipper in the normal Open position. Squeeze lightly at first and test the zipper. If the zipper continues to remain open squeeze more firmly with the pliers and try the zipper again. Repeat this procedure until the zipper operates correctly.

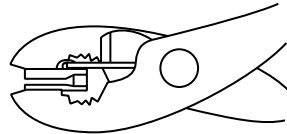
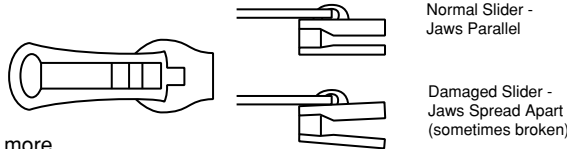

Water: Seeping through at the seams may be stopped by applying 3-M Scotchgard® on the inside of the seams. Rips in the fabric may be repaired with Bondex® iron on patches. Iron the patches to the Inside of the top, carefully following the Bondex® instructions.

Snaps: Keep snaps cleaned and lubricated with silicone to help prevent snaps from sticking to the studs. If a snap does become stuck to a stud, use a screwdriver and GENTLY pry apart to prevent permanent damage to the snap or the top fabric.

LIMITED WARRANTY

We warrant our product to be free from defects in material and workmanship, for the terms specified below, provided there has been normal use and proper maintenance. This warranty applies to the original purchaser only. All remedies under this warranty are limited to the repair or replacement of any item or items found by the factory to be defective within the time period specified.

If you have a warranty claim, first you must call our factory at the number below for instructions. You must retain proof of purchase and submit a copy with any items returned for warranty work. Upon completion of warranty work, if any, we will return the repaired or replaced item or items to you freight prepaid. Damage to our products caused by accidents, fire, vandalism, negligence, misinstallation, misuse, Acts of God, or by defective parts not manufactured by us, is not covered under this warranty.

THE WARRANTY TIME PERIOD IS AS FOLLOWS: ALL "SOFT GOODS" MANUFACTURED BY OUR COMPANY (USING PRIMARILY VINYL, PLASTICS, AND/OR FOAM): ONE YEAR FROM DATE OF PURCHASE.

ANY IMPLIED WARRANTIES OF MERCHANTABILITY AND/OR FITNESS FOR A PARTICULAR PURPOSE CREATED HEREBY ARE LIMITED IN DURATION TO THE SAME DURATION AND SCOPE AS THE EXPRESS WRITTEN WARRANTY. OUR COMPANY SHALL NOT BE LIABLE FOR ANY INCIDENTAL OR CONSEQUENTIAL DAMAGE.

Some states do not allow limitations on how long an implied warranty lasts, or the exclusion or limitation of incidental or consequential damages, so the above limitations or exclusions may not apply to you.

This warranty gives you specific legal rights, and you may also have other rights which vary from state to state.

For further information or request for warranty work, please contact:

Bestop Inc.
Customer Service
(800)346-3910
(303)465-1755